

Scottish Bridge News

The Official Magazine of the Scottish Bridge Union



Season's Greetings

Scottish Bridge News

Editorial

There has been a lot of bridge activity recently. We have reports on our Seniors at the World Bridge Games – details of scores and all the hands can be found at [2024 World Bridge Games](#)

The revived National League had an entry of 16 teams and was played over 2 weekends: if interested you can find the results in the Results Calendar on the SBU webpage.

The Scottish Cup Final has always been played face-to-face, with coverage on BBO. Hand records are in the BBO VuGraph Archive. This year it was held in the Carlton Bridge Club on December 14. It will soon be time to enter next year's event – a good opportunity to learn from more experienced players.

The Bidding Panel is run by Patrick Shields this time. All the contributors put

a lot of effort into this. Why not have a go at the problems, then compare your thinking with the panel and the Conductor?

Two appeals for help: you will see that this issue has been written almost exclusively by the editor. For variety, it would be nice to hear some other voices. Why not write a few words about a hand that piqued your interest, or an event that you enjoyed?

Also, a much-missed contributor was John Matheson. A book about him is a work in progress. We want to include 'John's Tips'. Those of you fortunate enough to learn from John are asked to contribute. Urgently!.

Please send to:

liz.mcgowan@blueyonder.co.uk

CONTENT

Issue 141

The 2024 World Bridge Games		2
Play Challenge Problems	Jim Patrick	4
The National League		5
Play Challenge Solutionss	Jim Patrick	7
The Scottish Cup Final		8
Crossword	"Finesse"	9
Simplifying Gazzilli	Iain Sime	11
The Highland Congress		13
December Bidding Panel	Patrick Shields	14
Panel Answers		23
December Problems		24
Crossword Solution		25

The World Bridge Games

Buenos Aires 2024

The first World Bridge Olympiad was held in 1960 in Turin. Any WBF affiliated NBO could send an Open team and a Women's team, and the four-yearly event soon grew. Scotland became eligible in time for the 2000 event in Maastricht and has been represented at each one since. In 2008 the event was renamed the World Bridge Games.

A Seniors competition was introduced in 2000, with a different format from the others. The Seniors played in a single group, initially in a Swiss format, later as all-play-all. It was brought into line with the other events in Beijing in 2008: 30 teams played in two Groups, the top eight teams in each group qualified for a knockout stage. Our Seniors have always paid their own way, and no Senior team travelled to Beijing. We did have Senior Teams in Lille in 2012 and Wroclaw in 2016. Because of Covid there was no event in 2020.

The SBU no longer subsidises its teams to this event, and our Seniors were the only players intrepid enough to travel to Buenos Aires this year. Numbers were down: there were just 24 teams in the Senior Round Robin, run as a single group with 16 teams to qualify for the knockout stages. Our team was Derek Diamond / Iain Sime; Cameron McLatchie / David Shenkin; Barnet Shenkin / Brian Spears; npc Maggie Shenkin.

During the Round Robin we performed steadily, never out of the top 10 till a heavy loss to India in the last round.

Barnet Shenkin found time to make a contribution to the Daily Bulletin:

"Cameron McLatchie was my first bridge partner in 1968 at Glasgow

University. He now spends his time between Jersey in the Channel Islands and Orlando where he is more used to playing golf than bridge. This year he accomplished the most amazing feat of following an eagle at a par 5 with a hole in 1 at the very next hole!!! Playing for Scotland with my cousin David Shenkin against Hong Kong China, in Round 14 of the Seniors he showed he can handle cards as well as clubs.

Bd 12	♠KT43 ♥Q3 ♦AK32 ♣T65	NSVul Dir W									
♠Q982 ♥A4 ♦T74 ♣AQJ4	<table border="1"><tr><td></td><td>N</td><td></td></tr><tr><td>W</td><td></td><td>E</td></tr><tr><td></td><td>S</td><td></td></tr></table>		N		W		E		S		♠J765 ♥976 ♦Q965 ♣32
	N										
W		E									
	S										
	♠A ♥KJT852 ♦J8 ♣K987										

WEST	NORTH	EAST	SOUTH
<i>Chan</i>	<i>Shenkin</i>	<i>Cheng</i>	<i>McLatchie</i>
1♣	Pass	Pass	1♥
Pass	2♣*	Pass	4♥
End			

West led the ♥A and played another. Cameron overtook and drew the last trump. He now made the key play of another trump. West had pitched a club but now had to pitch a spade or diamond. Whatever card West pitched declarer could unblock the ♠A, cross to dummy with a diamond and cash the ♠K before ruffing a spade. He would cross again with another diamond to ruff out West's last pointed card. West was down to ♣AQJ. Now Cameron exited with a low club to the ♣J to score the ♣K in the two-card ending. This was worth 10 IMPs as the opponents could only take 9 tricks in 3♥ - nice work Cameron."

Scotland faced India again in the Round of 16. This deal from the first 16-board segment produced many swings:

Bd 10	♠92 ♥JT432 ♦Q942 ♣Q5	All Vul Dir E									
♠KT6543 ♥9 ♦T76 ♣AK6	<table border="1"> <tr><td></td><td>N</td><td></td></tr> <tr><td>W</td><td></td><td>E</td></tr> <tr><td></td><td>S</td><td></td></tr> </table>		N		W		E		S		♠AQ7 ♥AK ♦AJ853 ♣T98
	N										
W		E									
	S										
	♠J8 ♥Q8765 ♦K ♣J7432										

WEST	NORTH	EAST	SOUTH
-	-	1♦	Pass
1♠	Pass	2NT	Pass
3♣	Pass	3♦	Pass
4♣	Pass	4♦	Pass
4♠	Pass	4NT	Pass
5♥	Pass	6♠	End

This was the Scottish auction. Approximately half the EW pairs bid slam, but most did not make it. With 11 tricks on top declarer's challenge is to avoid two diamond losers.

Successful declarers mostly chose elimination and endplay: they discarded a club on the ♥AK, cashed the ♠AK, drew trump and ruffed a club back to hand. Now some ducked a diamond to South, forcing a ruff and discard; others cashed the ♦A, planning to endplay whoever held Hx. This approach works well when trump break 2=2; if they do not there is still time for a successful diamond guess.

Others thought to establish diamonds for a club discard. They won the heart lead and cashed the ♦A at trick 2. If nothing happened, they would discard a diamond and concede a diamond,

hoping to establish the suit with a ruff. Something happened, and they drew trump and claimed their slam.

A third group discarded the losing club, drew trump and focussed on the best line in diamonds. This is a well-known combination: if North has Hx you lead to the Jack. South wins, but North's honour falls under the Ace next time. If South has Hx you lead the Ten and run it if North does not cover, then finesse the Jack next time; if North covers you win and play him for H9x by returning to hand and running the seven – if South started with 9x he is endplayed. With no indications from the auction most declarers guessed to play to the Jack, not best this time. An alternative, if South has Hx, is to lead a low diamond from dummy. One declarer did that, but when the expert South took the King he decided he must have KQ doubleton and went down anyway!

Scotland lost 17 imps on the board, the only sizeable swing in the set.

We were unlucky on another slam board from the last set, a vulnerable slam you want to be in, particularly in a match you are losing. It was not often bid, and made very rarely, notably by Sally Brock for the English Women's team.

Bd 25	♠J94 ♥J4 ♦Q86543 ♣84	EW Vul Dir N									
♠AK765 ♥KQ7 ♦A ♣AK72	<table border="1"> <tr><td></td><td>N</td><td></td></tr> <tr><td>W</td><td></td><td>E</td></tr> <tr><td></td><td>S</td><td></td></tr> </table>		N		W		E		S		♠T32 ♥A963 ♦KT9 ♣965
	N										
W		E									
	S										
	♠Q8 ♥T852 ♦J72 ♣QJT3										

WEST	NORTH	EAST	SOUTH
-	Pass	Pass	Pass
2♣	2♦	X	3♦
3♣	Pass	4♦	Pass
4NT	Pass	5♣	X
5♦	Pass	5♠	Pass
6♠	End		

On most leads the contract plays well. You play three rounds of trump, win the return and cash your remaining trump to squeeze South in hearts and clubs. But South's Lead-directing double is a killer. North leads a club. When he wins his spade trick a second club removes your entry to the club menace before you can cash the ♦K. (At some tables North opened 3♦, which gives a clue to the winning line on a club lead: cash ♣AK, ♥KQ and the ♦A before exiting with the third trump. North must return a diamond to the King. Declarer ruffs the last diamond and cashes the last trump to effect the squeeze.)

A pairs event was organised for players eliminated from the Teams. Barnet and Brian had a good run, and secured Scotland's first ever medal at a World Bridge Games, a bronze in the Senior Pairs.



Brian and Barnet at the medal ceremony.

Play Challenge

Jim Patrick

1 NS Vul Dealer East

♠KQJ
♥963
♦A953
♣A64

♠753
♥AKJT75
♦Q8
♣97

WEST	NORTH	EAST	SOUTH
1♣	Dbf	2♣	4♥
End			

Contract: 4♥ Lead: ♣Q

West leads the ♣Q which you duck. He then plays the ♣2 which you win. Both follow to your Ace of trumps. Can you find a line that is virtually 100%?

2 All Vul Dealer South

♠AQT95
♥84
♦JT9
♣AQT

♠K4
♥AT
♦AQ8642
♣KJ7

WEST	NORTH	EAST	SOUTH
-	-	-	1♦
Pass	1♠	Pass	3♦
Pass	4♣*	Pass	4♥
Pass	4NT	Pass	5♠
Pass	6♦	End	

Contract: 6♦ Lead: ♥2

4♣ is a cuebid agreeing diamonds

The heart lead hits you in your weak spot. How do you play?

Solutions on Page 12

The National League

The return of the National League saw an entry of 16 teams. The first weekend, in the Carlton BC, divided the field into two Divisions. The top 6 teams went into Division 1; the others into Division 2 for the second weekend in Glasgow.

When both pairs have a big fit there are a lot of tricks around. Here are a couple of swing boards from Session 2 of weekend 1,

Bd 3	♠A87 ♥T7653 ♦J42 ♣J3	EW Vul Dir S
♠9 ♥92 ♦A987 ♣KQ8654		♠KQT6432 ♥J ♦5 ♣AT92
	♠J5 ♥AKQ84 ♦KQT63 ♣7	

This one created double figure swings in 5 matches. Each side has a 10-card fit. EW can make 11 tricks in clubs; NS should make 10 in hearts. Par, 5♥X -1, was achieved at only two tables.

7 pairs scored 11 tricks in hearts. One West made the unfortunate lead of the ♣K, the others led their singleton spade. Declarer wins the ♠A, draws trump and knocks out the ♦A. East has ample opportunity to signal an entry in clubs, but West must have switched to the ♣K, which East saw no need to overtake. And so the spade winner was never cashed.

At 6 tables East was declarer in spades, mostly one down at the 5-level. The Double Dummy Solver makes 10 tricks with ease by dropping the doubleton ♠J. One declarer did just that and made

11 tricks to gain 13 imps. (To hold East to 10 tricks NS must organise a club ruff, not an obvious defence.)

West seems to have a normal 2♣ overcall of the 1♥ opener, so it is rather odd that only one EW pair played in clubs. Sadly, at the 6-level, presumably taking out insurance against 5♥.

Bd 20	♠AQT76542 ♥T ♦T ♣A65	All Vul Dir W
♠KJ ♥KJ5 ♦AKQ642 ♣Q7		♠— ♥9643 ♦J9873 ♣K983
	♠983 ♥AQ872 ♦7 ♣JT42	

This board features two 11-card fits. The par result is 6♦X-2, 500 to NS. That did not happen!

10 NS pairs played happily in spades. They made an overtrick by finessing against the ♠K then returning to dummy in trump to lead the ♣J. Some were pushed to 5♠, mostly doubled, to score 850. Top NS score went to the pairs who were doubled in 4♠ and made an overtrick. Only one NS pair failed to take the winning line in 5♠, losing 14 imps against 850 in the other room

6 EW pairs were allowed to play in 5♦. This can be beaten if North leads the singleton ♥T, but 3 pairs made. It seems odd that South did not compete to 5♣ after partner's pre-empt: you risk losing 5 imps when both contracts fail, but that is better than losing 15 when both make. The old adage: "When in doubt, bid one more" still has a lot going for it.

The second weekend was played in the Buchanan BC. 6 teams in Division 1 played 5 matches of 24 boards, changing opponents at half time. 10 teams in Division 2 played 9 12-board matches with a different timetable and different boards.

The 'Weak only' Multi has become very popular. This deal comes from Round 1 of Division 1:

Bd 2	♠KQ4	NS Vul
	♥K93	Dir E
	♦QJ9654	
	♣4	
♠J96		♠T85
♥2		♥AQJT6
♦AKT82		♦7
♣AQJ5		♣9763
	♠A732	
	♥8754	
	♦3	
	♣KT82	

At 4 of the 6 tables West played quietly in 2♣, scrambling home in spite of the bad breaks in the minors. One North tried a weak jump overcall. You might call him lucky, in that East did not fancy a negative double: still, 4 down vulnerable was 10 imps away.

At the 6th table East opened a Multi 2♦. West reckoned that partner's suit was hearts and decided to test his opponents' defensive methods by passing. North passed the test by passing. East, not gifted with X-ray vision, drifted 3 down.

The Multi may have affected results on this board from Round 3. According to Deep Finesse NS can make 10 tricks in any denomination except spades. EW can make 7 tricks in spades. One EW pair bought the contract in 5♠ undoubled, losing 200, which may have felt quite good at the time.

Bd 24	♠A	None Vul
	♥J863	Dir W
	♦AKQ87	
	♣KT2	
♠K98642		♠QJT53
♥52		♥AKQ
♦JT4		♦953
♣Q8		♣95
	♠A732	
	♥T974	
	♦62	
	♣AJ7643	

Most Wests opened a Weak2, doubled by North. 4 NS pairs landed in clubs at various levels. Those playing a Multi had a clue about the lead when partner bid 3♥ over the double; at other tables West led a spade. Now declarer has 12 tricks, assuming a good view in clubs. Only one declarer played 'Nine Never' – the South who was allowed to play in 4♣. The other two, not gifted with DF's second sight, played West for a singleton club.



Winners of the John Matheson Trophy: from left: Antone Huang, Paul Barton, Miro Dragic, Jun Nakamaru-Pinder, Robert Ferrari.

Division 2 was won by Robert Clow, Troy van de l'Isle. Mike McGinley and David Wiseman

Play Challenge Solutions

Jim Patrick

1 NS Vul Dealer East

	♠KQJ	
	♥963	
	♦A953	
	♣A64	
♠AT42		♠986
♥4		♥Q82
♦KJ42		♦T76
♣QJT2		♣K853
	♠753	
	♥AKJT75	
	♦Q8	
	♣97	

WEST	NORTH	EAST	SOUTH
1♣	Dbl	2♣	4♥
End			

Contract: 4♥ Lead: ♣Q

West leads the ♣Q which you duck. He then plays the ♣2 which you win. Both follow to your Ace of trumps. Can you find a line that is virtually 100%?

It looks as if the clubs are 4-4, and East has the ♠K. There is a danger of losing one trick in each suit. To avoid this you can try to endplay West. It must be safe to play spades since West is marked with the ♠A and East is very unlikely to have 5.

Play a spade to dummy and ruff the last club before playing a second spade which West must take to exit safely on a spade. Now you can safely take the trump finesse for if it loses, West is endplayed.

2 All Vul Dealer South

	♠AQT95	
	♥84	
	♦JT9	
	♣AQT	
♠J6		♠8732
♥KJ62		♥Q9653
♦K5		♦73
♣86543		♣92
	♠K4	
	♥AT	
	♦AQ8642	
	♣KJ7	

WEST	NORTH	EAST	SOUTH
-	-	-	1♦
Pass	1♠	Pass	3♦
Pass	4♣	Pass	4♥
Pass	4NT	Pass	5♣
Pass	6♦	End	

Contract: 6♦ Lead: ♥2

A straightforward diamond finesse gives you around a 50% chance. (Assuming the lead to be 4th best, West is more likely than East to have the ♦K but, if East has a diamond void, you can try 3 rounds of spades.) Does it improve your chances to cash the Ace of trumps and play spades?

It seems that this only helps when you fell a singleton ♦K or the spades are 3-3. But you also make if East has ♠Jx even if he has 4 trumps. (He ruffs the third spade, you overruff and cross with a club to play a fourth. He ruffs, you overruff and cross with a club to play the last spade, throwing your losing heart. Only a very bad club break beats you.) And you make when West has Jx in spades provided he has a singleton or king doubleton trump.

The probability of an even break in spades increases (from 35% to 38%) when hearts are known to be 5-4. As is usual, combining your chances increases your rate of success - here from less than 48% to over 59%.

The Scottish Cup Final

This was played in the Carlton Bridge Club on Saturday 14 December. The holders, SHORT, faced the young pretenders: Paul Barton, Jake Milne, Jun Nakamaru-Pinder and Antone Huang.

The boards were exciting – or did the players make them so? Of 64 boards only 13 were flat! If you look in the BBO VuGraph archive you see that 372 imps changed hands in just 64 boards, averaging nearly 6 imps per board. (Boards 55 and 56 were switched, so the totals are slightly different, but still impressive)

Some of the many swings were on slam boards.

Bd 23	♠AJ2 ♥KQJ7 ♦J543 ♣T2	All Vul Dir S
♠T95 ♥T954 ♦Q2 ♣KQ94		♠K ♥A8632 ♦T876 ♣763
	♠Q87643 ♥— ♦AK9 ♣AJ85	

The SHORT team stopped safely in 4♠. West led his doubleton ♦Q and declarer emerged with 10 tricks. The BARTON NS pair had a long scientific auction to 6♠, in the course of which East doubled for a heart lead. When West led a heart declarer has a chance: just drop the singleton ♠K and the doubleton ♦Q...

Two more slam boards appeared towards the end of the match

Bd 53	♠AJ53 ♥AKJ7 ♦9 ♣KT54	NS Vul Dir N
♠Q8 ♥986543 ♦65 ♣A98		♠T76 ♥T2 ♦J8743 ♣J62
	♠K942 ♥Q ♦AKQT2 ♣Q73	

Both Norths opened an off-centre strong no-trump. South used Stayman, then bid a forcing 3♦ over 2♥ to find the spade fit. RKC told North that the partnership was missing one Keycard and the trump Queen. The youngsters, behind in the match, bid slam anyway. Their elders were more circumspect, and so lost 13 imps on a finesse.

Bd 54	♠K87 ♥4 ♦KQ97 ♣K8543	All Vul Dir E
♠AJT2 ♥AJT932 ♦3 ♣A9		♠Q964 ♥KQ7 ♦A54 ♣JT2
	♠53 ♥865 ♦JT862 ♣Q76	

WEST	NORTH	EAST	SOUTH
-	-	1♣	Pass
1♥	Pass	1NT	Pass
2♦	Pass	2♥	Pass
4♦	Pass	4NT	Pass
5♦	Pass	5NT	Pass
6♥	End		

The younger team pulled out all the stops. 2♦ was an artificial game force.

East showed his 3-card heart support, and West splintered in diamonds. RKC unearthed 3 Aces and 5NT was a Grand Slam try. But there was there was an inevitable club loser: when the spade finesse failed so did the contract.

Over 2♦ most partnerships show Major suit features – 3-card support or an unbid 4-card Major – upwards. Is it better to show the unbid Major first?

The other East opened a weak no-trump. West used Stayman to find the 4=4 spade fit. 6♠ is a better slam. It makes when the spade finesse works, and when North does not lead the killing club. The normal lead is ♦K, but if East splinters in that suit... who knows?

The holders opted to pass 4♠. North led an optimistic singleton and 12 tricks rolled home. 12 imps that might so easily have gone the other way.

Congratulations to Brian Short, who has now won 16 Scottish Cups, closing in on John Matheson's record of 18.



The winners: Gints Freimanis, Derek Sanders, Brian Short, Alan Goodman

Crossword by 'Finesse'

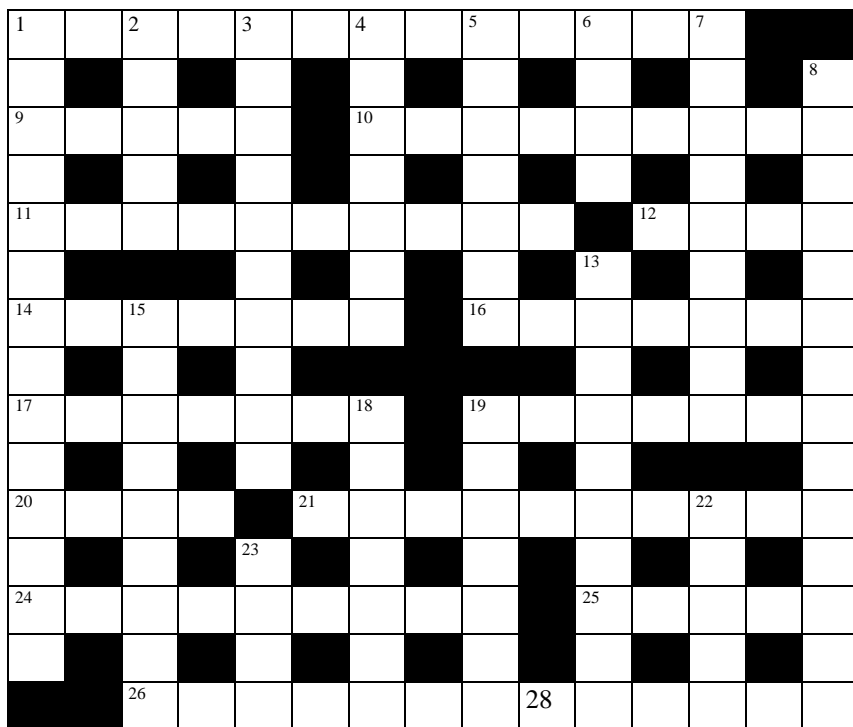

Crossword Clues

ACROSS

- 1 Spouting a load of drivel is about the norm for this pet (7,6)
- 9 Enjoy the best of meals though without having a starter (3,2)
- 10 One would be moved for a girl after the French jewellery (9)
- 11 MOT and repairs affected transport network (5,5)
- 12 Chin undergoes surgery to become part of a foot! (4)
- 14 Go bust as steady regulars refuse to budge (7)
- 16 Keen after odd social climbers come here (7)
- 17 Their job potentially is to read article to be rejected (7)
- 19 One strips off for a massage (7)
- 20 Star of the Miami Dolphins (4)
- 21 Reportedly inferior standard set for a preliminary conference (10)
- 24 This fieldsman is not what you would call quick! (9)
- 25 See 7
- 26 Holiday funds in Scottish currency running out before the start of the week (8,5)

Down

- 1 A chatterbox? (9,5)
- 2 The French parent almost becomes persona non grata (5)
- 3 Opinions differ about computer systems deployed (2,8)
- 4 Building regally constructed and largely refurbished (7)
- 5 Publicity-starved review (7)
- 6 Regularly feel sorry about part played (4)
- 7 and 25 Most of Hansel and Gretel has been rewritten - not about escaping witch but escaping spirit (3,6,5)
- 8 Operation to reshape bunker guarding seventeenth green at the home of golf? (7,7)
- 13 Musical apt to make money (7,3)
- 15 Specs could be free of charge in pilot schemes (9)
- 18 Hunted with dogs, succeeded to come first, still hunted (7)
- 19 Shy away from touch (5-2)
- 22 Take in lodgers primarily to make a living (5)
- 23 Said to be top dog (4)

Solution on Page 25

Simplifying Gazzilli

Iain Sime

My most successful bridge partnership has been with John Matheson who sadly passed away in September. John was great at watching and learning from the best players in the world. Mostly he did so on BBO Vugraph, but he had other sources of study, most notably the *Bridge World* magazine.

John would pick up on the latest conventions and introduce them into our bidding system. One of these was Gazzilli which, as its name suggests, is an Italian invention. I can verify that Gazzilli was a points winner. It enabled us to set up a game force at a low level; it also stopped us from over-reaching by trying for game when we belonged at the two-level.

The classical version which we played included a lot of artificial bids. These were a memory strain and perhaps the reason why many tournament players have overlooked the advantages. In my partnership with Derek Diamond, we have eliminated all the artificial bids except two. *The two which remain are called "bucket bids" where we have values for game but need help to find the right strain.* This is similar to Fourth Suit Game Forcing.

Perhaps simplification will make Gazzilli more appealing to Scottish players looking to improve their results. Whilst it is possible to include Gazzilli in an Acol-based system, it is more effective in the 15/17 NT, 5-card majors, 2/1 Game Forcing system employed by most international players.

What is Gazzilli?

a. Gazzilli applies in the following 3 sequences:

- 1♥-1♠-2♣
- 1♥-1NT-2♣
- 1♠-1NT-2♣

The 2♣ bid by opener is either natural, 11-15 points, or any 16+.

- b. A 2♦ response shows a **good** 8+ points and is Forcing to Game (FG) opposite the 16+ option, i.e. when opener does not rebid 2 of his major.
- c. After a limited hand is shown by non-Gazzilli, bidding is normal but courtesy raises are not required.
- d. Jump rebids (which would otherwise have been needed to show extra values) show limited hands (13-15) with good playing strength; see Intermediate Strong Distributional (ISD) below.

Simplifying Gazzilli- Making bids mean what they say.

1. The 2NT rebid showing a 6/4 ISD was not pulling its weight. In 10+-years playing with Johns Matheson and Murdoch, it came up once. Derek and I agreed that it would be productive to use 2NT as 18/19 balanced (5332) taking that fairly common hand out of Gazzilli 2♣.
2. After 1♥-1♠-2♣-2♦, using 2NT as a bucket by opener and 3♣ as 2533 feels wrong. We changed to 2NT is 2533 16/17 and otherwise bid your extra length. That also brings the 2NT (16/17) bid into line with 1♥/♠-1NT-2♣-2♦-2NT. Note that we can also open 1NT with that 5332 shape and would do so with "soft"

values, i.e. Queens and Jacks, and a decent doubleton.

3. After all these Game Forcing 2NTs responder can bid a new suit at the 3-level if he feels that 3NT is not best. After 1♥-1♠-2NT (18/19), responder should be aware that a 5/3 spade fit is still possible.
4. Another bid which rarely happened was 1♠-1NT-2♣-3♥, invitational with 5/6 hearts. And a problem if opener is 11/15 blacks. So deleted; responder if unable to bid 3♥ over 1♠, responder bids 2♦ and hopes to show the fifth heart next, e.g. 1♠-1NT-2♣-2♦-2♥/2NT-3♥.

So, what does our Gazzilli look like now?

Gazzilli after 1♠-1NT-2♣-?

2♦ = any good 8+, continuations below.

2♥ = 5-8, either 6 hearts and 1-2 spades, or 5 hearts and one spade ;

2♠ = 5-8, 2 spades, occasionally one if 1444,1453,1435 Opener usually passes even with 16-17, bids on naturally with 18+.

2NT= 5-8, 0/1 spade, 5/4+ in minors

3♣♦ = 5-8, something like 1 spade and 6 of the minor.

After 2♦ relay – 1♠-1NT-2♣-2♦-?

All bids show 16+ and are FG except 2♠ = 5 spades, 4+clubs, 11-15.

2♥* = 5 spades, 4 hearts or 6 moderate spades. Now 2♠ spades shows Hx, 2NT- 1 spade or a small doubleton, others natural.

2NT= 16-17, 5(332)

3♣/♦/♥ = 5-5+

3♠ = good 6 spades

3NT 6(322) NT orientation

Gazzilli after 1♥-1NT- 2♣-?

Structure and responses as for 1♠-1NT, but 1♥-1NT-2♠ is a normal reverse.

After 1♥-1NT-2♣-2♦-?

All bids show 16+ and are FG except 2♥ = 5 hearts, 4+clubs, 11-15.

2♠* = 5 (or moderate 6) hearts, 4 spades, 22 or unbalanced

2NT= 16-17, 5 hearts (332)

3♣/♦ = 5-5+

3♥ = good 6 hearts

3NT 6 hearts (322) NT orientation

**These are the bucket bids on strong hands after 1M-1NT-2♣-2♦ (FG but which game?).*

Gazzilli after 1♥-1♠-?

Opener holding four spades makes a normal raise.

After 1♥-1♠-2♣-responses are the same as 1♥-1NT-2♣-except 3♥ is invitational with 3♥, usually 5 spades.

John Matheson was very enthusiastic about Gazzilli and wrote several articles about it in the SBNews.

If you Google the convention you will find at least 18 slightly different versions, but the basic principle is the same.

It is highly recommended for use in a strong no-trump system. As Iain points out, it does not blend well with a weak no-trump,

The Highland Congress

The Highland District Congress has a fine reputation everywhere. (On one of the EBL Women's training days we met someone from Portugal with fond memories of Aviemore.)

Last year the Congress celebrated its 50th anniversary with a return to Coylumbridge. Sadly, they could not book their traditional second weekend in November this year, which meant some regulars could not attend. Next year they return to the traditional date, and we hope that numbers will grow. It is a great weekend, an opportunity to brighten November gloom by meeting old friends and making new ones.

This deal from the Teams Final helped the winners on their way.

Bd 23	♠Q83 ♥KT643 ♦J8 ♣842	All Vul Dir S
♠K952 ♥A ♦A754 ♣J653		♠AT7 ♥J87 ♦Q932 ♣KT9
	♠J64 ♥Q952 ♦KT6 ♣AQ7	

WEST	NORTH	EAST	SOUTH
-	-	-	1♣
Pass	1♥	Pass	2♥
Dbl	Pass	?	

West has no good call over the 1♣ opener. But when South raises hearts he is worth a takeout double. This shows opening strength in the middle of a live auction, but it gives partner a headache. East saw no good bid on this hand and decided to Pass. He led a trump to West's Ace.

But there is no way to defeat 2♥. Say West switches to a club. Declarer wins, draws trump and leads the ♦J from dummy. East covers, West wins and returns a club. Declarer cashes the ♦T and ruffs his last diamond. He has made 6 tricks, and exits with a club in this position:

Bd 23	♠Q83 ♥T ♦- ♣8	All Vul Dir S
♠K95 ♥- ♦- ♣J6		♠AT7 ♥- ♦9 ♣T
	♠J64 ♥9 ♦- ♣7	

The defender who wins the club must either open up spades or concede a ruff and discard. Tough!

East does better to bite the bullet and choose between 2♠, a 4=3 fit. and 3♦, a level higher and possibly another 4=3 fit. He will do well to make 2♠, but -100 is better than -670.

Note the diamond intrafinesse position. Since South is favourite to hold the ♦K declarer leads ♦4 from dummy and covers North's ♦8 with the ♦9, losing to South's ♦T. Later he leads the ♦Q from hand to scoop North's ♦J and lose only one diamond trick. Something to boast about at dinner!

The Congress was a triumph for Emily Garden and Bill Ross who carried Liz McGowan and Fiona McQuaker to victory in both the Teams and the Sunday night Swiss. The Pairs were won by Tim McKay and Abi Wilson. And the Bidding Competition ended in a tie

Bidding Challenge

December 2024

Patrick Shields

We have 17 panellists this month from whom to distil wisdom about how to bid these hands – all of which come from recent events. We welcome to Norman Selway and Kay Preddy, England Internationals from Kent who brings a wealth of experience to bear on these problems. Four problems produced a majority score and there was always one answer getting at least 7 votes on each deal, so there is guidance to offer.

Problem 1 Teams Both Vul

♠QJ87432	S	W	N	E
♥JT9		1♦	2♣	P
♦983	?			
♣--				

This deal arose in an inter-County match. The field divided evenly on the two options – pass and 2♠. There is, roughly speaking, one downside to bidding (you get too high) but two downsides to passing (missing a spade game, going negative in a club part-score when a positive is available in spades). It ought to come down to the balance of probabilities of the different outcomes – except that your pass might not end the auction. Some who passed looked longingly to that possibility.

GORDON: PASS. I am quite likely to have another bid. Meanwhile I can listen.

SELWAY: PASS. If, as expected it then goes double-P-P I can bid.

SIME: PASS. If I pass, odds are that West is too strong not to balance.

PEDEN: PASS. I pass just now as it's highly likely that West will bid or double.

PREDDY: PASS. I expect to be able to bid again. 4♠ is too much - I have too many losers and partner may have only club values. 2♠ too strong, and 3♠ a fit jump. Over double-P-P I might consider 3♠.

The problem is that you are so short in clubs that the opponents are likely to pass. The other passers were more pessimistic:

ASH: PASS. I was told “When you have a misfit – stop bidding!” and I have found it to be good advice.

SHORT: PASS. 2♠ is simply silly as it is probably forcing and will get us too high in all probability.

All are happy to run after double-P-P.

PIPER: PASS. Obviously, you start bidding spades over a double.

MCGINLEY: PASS. Then if a re-opening double by West is left in, I'll bid 2♠.

Mike also mentioned the use of Transfer Advances of Overcalls – which would allow you a non-forcing and a forcing bid in spades. Only one panellist pondered whether or not 2♠ was forcing but the consensus is that it must be.

The bidders could see the dangers but were more optimistic.

DRAGIC: 2♠. This wins over Pass in the case of us having spade fit and if we need to make it difficult for them to bid their game in hearts or no-trumps.

SMITH: 2♠. I play this as forcing for one round and will rebid 3♠, non-forcing, over the likely 3♣ from partner. Playing in clubs my hand will be valueless as dummy, but it has great trick-taking potential if played in my long suit. Opposite the wrong hand we could be looking at a big penalty, but partner will only raise with some appropriate values, and then I'd fancy our chances.

WHYTE: 2♠. Choice is between 2♠, 3♠ or 4♠. My choice is 2♠ due to having too many potential red-suited losers.

When the hand arose partner had a useful K-A852-JT-AK7653 and game in spades was a photo finish, but in clubs you were set for -300.

The clear choice of the panel is to pass on this hand, and we must respect that while acknowledging that sometimes the alternative can work out well also.

Problem 1	Votes	Marks
Pass	14	10
2♠	3	6
3♠, 4♠	0	2

Problem 2 Teams E/W Vul

♠--	S	W	N	E
♥7	-	-	-	1♥
♦AKQT74	?			
♣T97543				

Two questions must be answered in bidding this hand – one is how high to go and the other is what you want to be the trump suit. One consideration these days is that many tournament players are well rehearsed in how to bid over an unusual 2NT, and the systems they have – geared to showing the majors – look likely to work very well for them here. Some very experienced voices suggested a softly-softly approach ...

SIME: 2♦. [Bidding] 2NT or 4NT risks an unwelcome club preference, or a club lead. If partner supports diamonds, it will be tough for the defenders to envisage 6/6.

ASH: 2♦. I am sure most will bid 2NT, showing both minors, but I simply can't bring myself to not stress these wonderful diamonds.

PREDDY: 2♦. And then 4NT at some later point.... diamonds is the lead that I want if I defend.

Showing our shape can help them if they end up declaring, as pointed out by

SHORT: 2♦. 2NT gives too much away regarding my shape.

The rest of the panel were divided between bidding 2N and 4N – both showing the minors but the latter suggesting more shape at the same time as using a lot more space. The vast majority went for the higher bid.

VALENTINE: 4NT. I will be competing to 5m regardless. I may as well reduce the time that they have to exchange information to judge the hand.

SELWAY & SMITH identically: **4NT.** Tells partner I have 11-12 minor suit cards and uses all of their space.

GORDON: 4NT. Maximum pressure. The objective here is to buy the contract when it's making or is a good sacrifice. After 4NT, I can pass anything that partner doubles, having promised no defence.

But he did acknowledge

GORDON:I also like 3♦ over 1♥ in case partner is on lead. That has the additional benefit of hiding my 66 when I compete in clubs later.

Two who settled for the lesser 2N also had their reasons, best explained by

FREIMANIS: 2NT. I will start off by showing both minors and likely make some more bids later on. Could bid 4NT, but it can be beneficial to make a bid at a lower level to see how far partner is ready to support us voluntarily.

At the table the 2♦ overcaller was forced into bidding 5♦ unilaterally at the end, and the opposition knew by then what they held and could act accordingly. Grabbing all the space immediately must be best, but it is unclear whether it is better to show or to hide the second suit.

Problem 2	Votes	Marks
4NT	9	10
2♦	5	5
3♦,4♦,5♦	0	7
2NT	3	3
others		0

Problem 3 Teams E/W Vul

♠72	S	W	N	E
♥AJT854		-		1♣
♦AQ4	1♥	1♠	2♦	2♠
♣A6	?			

This problem produced five different answers but almost half the panel went for just one of those. The difficulty is that there are three things you want to show – the extra values, the diamonds support, and the sixth heart. How do you go about that? The first option to consider – when you have it available – is a double which basically tells partner “I am too good to pass, tell me more about your hand”

SHORT: DBL. By far the most flexible call. Doubles of a supported suit at a low level are never penalty ... I cannot see how any other bid can be nearly as good.

DRAGIC: DBL. Extra values, looking for the best fit. 3♦ would be an underbid and 4♦ is too committal.

SIME: DBL. Let's see if we can find out more about partner's hand.

It's very hard to disagree with that and the bidders offered little reason for skipping this choice. There was just one who chose to emphasise the hearts –

CLOW: 3♥. I expect partner to bid again after I make this free bid.

And one whose imagination outstrips that of most players –

WHYTE: 3NT. This can be a shoo-in even if partner has no spade stopper as long as that suit is split 4-4. Partner should have at least six diamonds, and if he has no high outside card then he should have seven. 3♣ is the text-book bid, but against that is my firm conclusion that 5♦ will have no chance and 4♥ is unlikely to make, so 3NT is the only game in town. Best bid it to be sure that it is the final contract.

The other panellists went for a cue bid. Some bid a suit to show a stopper.

MCGINLEY: 3♣. Forward-going, showing stop in clubs but not spades.

GORDON: 3♣. Invitational in diamonds and a club stopper. With a spade stopper, I bid 3♣, and 2NT with both.

Others bid a suit to deny a stopper

FREIMANIS & VALENTINE: 3♠. Will ask for a stop and ...

That makes a cue bid a dangerous choice. The other implications of using the cue bid are also worth exploring, particularly the higher cue which leaves little space.

SELWAY: 3♠. Must have a diamond fit and gets partner to bid 3NT with a stopper. Will bid 5♦ if they bid 4♠.

PIPER: 3♠. I am worried about missing a 6-2 heart fit: over 3NT/4♦ I'll try 4♥.

FREIMANIS: 3♠. will ... advertise a very good hand in context.

We see the direction of travel varies by bidder, so how can partner know what to expect? The fact of such uncertainty makes the argument of the doublers sound so much better. On the day 3NT had nine running tricks, and 6♦ was makeable with the very favourable lie of the cards.

Problem 3	Votes	Marks
3♠	8	10
Dbl	4	9
3♣	3	8
3♥	1	3
3NT	1	3
others	0	0

Problem 4 Teams N/S Vul

♠T2	S	W	N	E
♥AK5	-	-	-	3♦
♦T64	?			
♣AKJ62				

This feels like a common problem. We are just a little (a single hcp?) above a weak no-trump opener and want to bid but it is hard to describe our hand at this high level. The panel voted strongly (12 to 5) for inaction, some without expressing much concern.

CLOW: PASS. Nothing to say at the moment.

WHYTE: PASS. When fixed, stay fixed.

Others searched around for an alternative before passing.

FREIMANIS: PASS. Not ideal given the values, but with only 2-3 in the majors seems like taking any action could prove to be misleading and risky.

PREDDY: PASS. Though 3NT is possible. Obviously a bit strong for pass but can't double and have no diamond stop.

Some passers still hoped to bid later.

MCKAY: PASS. Partner is still there.

PIPER: PASS. Relying on partner. Don't like it.

SHORT: PASS. My well-trained partner will protect if shape suitable. Particularly at this vulnerability, a bid is seriously dangerous in my view.

The bidders fell into two camps. There were those who doubled and crossed their fingers hoping partner would not embarrass them –

SMITH: DBL. This is one of those horrible situations where any action you take is wrong, but the worst action of all is pass.

ROSS: DBL. I don't particularly like it but feel I must do something.

VALENTINE: DBL. I have to take some action. 4♣ wouldn't be natural and it goes past 3N. The worst that happens is that partner bids 4♠ and I don't feel comfortable.

They might get lucky, but two panellist decided to make their own luck – and getting lucky this way is not so incredible given the pre-empts we see these days.

ASH: 3NT. Bid as confidently as is legal! Of course, we risk looking very silly but I cannot bring myself to Pass. Most play 4♣ as a two suiter these days and double risks an even bigger calamity.

SELWAY: 3NT. Amazing how often 10xx is a stopper and the bidding may not stop there.

Although we have all had our fingers burned by taking action in dangerous circumstances, we have also seen

others take action and escape unscathed. What does this example tell us? Just that cautious bidders hold sway in 2024 – but if we ask in another year then who knows?

[This hand arose in a Gold Cup match and partner had a 13-count with a 4-3-3-3 shape and partner can make 3NT but we cannot]

Problem 4	Votes	Marks
Pass	12	10
3NT	2	8
Dbl	3	6
Others	0	0

Problem 5 Teams E/W Vul

♠KQT8	S	W	N	E
♥AQ63	2♣	2♦	Dbl	P
♦QT	?			
♣AQJ				

2♣=20-21 flat or game force

Dbl=some values, nothing to emphasise

The methods here were not familiar to everyone but it is right to stretch a positive in competition, and you need to distinguish between nothing and a few values. This approach does allow one possibility that other methods preclude, viz

GORDON: PASS. Hope to make a plus score.

It was surprising that so few went for pass at this vulnerability, given that we have good prospects of keeping declarer to diamond winners and no more. It did get mentioned by some others.

ASH: 3♦. Pass is an option – hoping to at least get a plus score – but I would much prefer to be able to open 2NT with this range of balanced hand, using 2♣ for

stronger balanced hands. Then passing is a lot safer.

SIME: 3♦. Unless West is on my lunatics list.

The big question was how do we go about describing our hand to partner after this start? We had intended to bid 2NT on the second round before West rang the alarm bells about the diamond suit. Some felt it best to continue down that path.

SELWAY: 2NT. Reese always said that Qx was a good holding for NT, avoids wrong siding the contract and this brings in Stayman and transfers.

SMITH: 2NT. If they have a major, partner will look for the major game. If none, they are likely to have some length in diamonds and we must hope that includes the Jack or better. Bidding 3♦ now could wrong-side a possible 3NT and have no gain over 2NT in finding a major fit.

FREIMANIS: 2NT. The 2♦ bid is often going to be made on very few values after a strong opening bid, so a lack of full stopper is unlikely to cost us.

But a larger number opted to bid 3♦; the bid might make partner scratch their head but unless they read it as 5-5 in the majors, you will hear from them whether they have a four-card major and if not whether they have a diamond stop. Not that they need much to stop diamonds.

DRAGIC: 3♦. With a balanced hand and a diamond stop I would bid NT; with GF unbalanced hand I would bid my suit. So partner should read that I am balanced with no diamond stop.

Some thought they were showing more than asking.

McKAY: 3♦. Trying to show both majors.

PREDDY: 3♦. Tricky as if partner has Ax or Axx or Kxx then I probably want to play in 3NT rather than be dummy. Maybe 3NT over partner's major shows what I have, if I have already shown both majors.

There were a couple of mavericks.

WHYTE: 2♥. Of course, a pass is semi-tempting at this vulnerability, but I have no taste for having to explain to our team-mates how we allowed our oppo to play in 2♦x making, or even minus one trick for 200, when we had a slam dunk major suit game.

McGINLEY: 4♦. Asking partner to pick a major. Other calls (pass, 2NT, 3♦) are unattractive.

When the hand occurred in the Tollemache Final in February 2024, pass was the winning action as partner had AJ4-T92-9873-T92 and the rest of the field played in 3NT-1. Who knows what partner might do over 3♦.

What do we learn from the above? The main message is that we would not have had a problem to discuss if there had been no intervention. Most partnerships have put very limited planning into 2♣ auctions when the opponents compete. That makes intervention more worthwhile.

Problem 5	Votes	Marks
3♦	8	10
2NT	6	8
Pass	1	9
2♥	1	5
4♦	1	2
other	0	0

Problem 6 Teams N/S Vul

♠72	S	W	N	E
♥AQT872	-	3♣	3♣	P
♦KJ82	?			
♣A				

After a gentle pre-empt we are presented with a problem because we have a good hand and limited space in which to describe it. We cannot tell at this point whether the best denomination is spades or hearts or diamonds. Much depends on what sort of suit we expect partner to introduce at the 3-level, vulnerable. Surely it should be better than we expect for a 1-level overcall. This thinking allowed a few panellists to fix on spades.

SHORT: 4♠. Partner would bid 3♣ with AQ10xxx-xx-Ax-xxx, so I can't really explore higher without risk, when our suits could break badly. After pre-empts, players should double first and bid their suit a little more freely than over low-level openers, specifically to disentangle these sort of situations.

McKAY: 4♠. A "practical" bid.

The downside is that partner knows little about your strength. Some others were not so sure about the denomination and made a choice which partner is allowed to over-rule.

SELWAY: 4♥. If partner's spades are long and strong they will convert but sometimes they have a decent hand with a poorer suit. I hope 4♥ caters for this.

WHYTE: 4♥. It is almost a toss-up whether to bid 4♥ or 4♠, but if there is a bad trump break, I have a much better chance playing in hearts rather than spades.

DRAGIC: 4♥. Not forcing but if partner pulls to 4♣, I will go on.

Some others felt 4♥ was the end of the line and so avoided that choice.

ASH: 4♣. 4♥ would be to play, but is very unlikely to play better than in spades.

CLOW: 4♣. If I bid 4♥ we are very likely to play there.

The majority postponed the problem by starting with the cue bid. We lack unanimity about its meaning.

PREDDY: 4♣. I don't think this is necessarily a spade raise as the level is so high I need to be able to show any good hand. It is my only strong bid. The problem I think comes next and what do partner's responses mean?

FREIMANIS: 4♣. I'll start off by showing a good raise to game even though I do not have a full fit for spades, since partner is likely to have at least six of them, although sometimes partner will not have full values for a 3♣ bid.

GORDON: 4♣. Cue. I like partner to bid a suit, if any, now. Small slam seems quite likely – you are already favourite to have a spade fit.

Some felt the cue had to be avoided

PEDEN: 4♥. I can't bid 4♣ agreeing spades so I bid 4♥.

My favourite analysis of the 4♣ bid is

SIME: 4♣. I can kick this problem into touch for a round. Maybe something good will happen.

The key point is that we don't know where we want to play, and the lowest possible bid is the one leaving most chance to find out. Kay asks the key question that we might come back to – what does partner's next bid mean?

Problem 6	Votes	Marks
4♣	9	10
4♥	6	8
4♠	2	4
other	0	0

Problem 7 Teams N/S Vul

♠AKQ7653	S	W	N	E
♥43	-	-	-	2♥
♦AKQ8	Dbl	3♥	P	P
♣--	?			

2♥ = weak two bid

One doesn't often get hands as strong as this, but it is important that you handle them well, and that partner understands what you are doing. We had five different answers on this problem. The majority gave the clear message to partner that they had a strong single suiter. The key question is just how strong a hand does 4♣ show?

ASH: 4♣. As I didn't bid game on the first round, partner will expect me to have a really strong hand.

GORDON: 4♣. You are too good to bid 2♠, 3♠(strong) or 4♠ over 2♥. Or 3♠ over 3♥. So 4♣ now delivers a great hand of nine-ten tricks – but not really as good a hand as you have. However, if you double again, partner might bid 5♣ and we find 5♣ might be one off.

A number of others felt the inclination to bid higher but were worried.

SIME: 4♣. Probably we have two losers. Sometimes fewer, sometimes more.

SHORT: 4♣. Somewhat tempting to look like an expert and bid 5♣ (“eleven in my own hand, but two heart losers”) but we could have a spade or/and a diamond loser as well as a heart or two.

That didn't stop a serious minority from venturing to the 5-level.

DRAGIC: 5♠. Asking partner to bid slam with heart control. Probability that the fourth diamond is covered is well over 50%.

SMITH: 5♠. Go to slam partner if you don't have two heart losers.

MCGINLEY: 5♠. Wanting partner to look at his doubleton heart and decide.

Some tried to indicate their strength without forcing to the 5-level.

PREDDY: DBL. Over partner's expected club bid I will bid 4/5♠.

MCKAY: 4♥. Seeking more information.

SELWAY: 4♥. A strong one suiter, not giving up on a slam opposite a single heart and zero points.

One might learn something from these choices but it is hard to see partner understanding your hand any better. This next bidder might be showing a strong single suiter but I fear he is on a different page from the other panellists.

WHYTE: 5♥. A bid of the opponent's suit at a high level is not showing a control, it is asking for a control.

The hand arose in a head-to-head match and the cold slam (partner has ♥AT) was missed at both tables Miro explained it well above – you have to take the risk of bidding to the five level, if you are to find any slam.

Problem 7	Votes	Marks
4♠	8	10
5♠	5	10
4♥	2	6
Dbl	1	6
5♥	1	1
other	0	0

Problem 8 Teams N/S Vul

♠A943	S	W	N	E
♥Q8	-	-	P	1N
♦9876	P	2♦	P	2♥
♣KT5	P	3NT	End	

2♦=transfer

What is your lead?

Sometimes the prospects of defeating their contract are not great, and even if there are good chances the path may not be clear. We cannot tell from this auction whether dummy will produce a minimum or significant extras, but if we are to beat the contract our assumption needs to be that dummy is a minimum, and that means partner will have around 6-7 high card points (40 less 9 less 24-25). Our strength is almost evenly split. There was strong consideration of the need to make a safe lead.

SIME: ♦8. Hearts are not breaking for declarer, so I am going passive.

MCKAY: ♦8. Trying not to give anything away.

PREDDY: ♦8. It looks like I want to minimise my chance of giving tricks on the lead.

SELWAY: ♦8. A boring second highest from bad and I know partner did not double 2♦; with hearts rating to be 4-2, I hope to get a second chance if I am wrong. Any other lead might give the ninth trick.

DRAGIC: ♦8. I prefer to lead from a sequence: it could work if passive defence is required or if partner can beat dummy's diamond honour.

SMITH: ♦8. Definitely not hearts, and both black suit leads look very unattractive. As so often with leading, I pick the least bad.

Passive has a lot going for it, but it is worth noting that almost no lead is without risk. The lead of an eight might well place missing diamond honours for declarer and cost you a trick. The second most popular candidate lead was a spade, and the key consideration in that suit is given by

GORDON: ♠3. The ♠9 could be promising.

Crucially, the nine is the card we are attempting to make into a winner, and we should be glad our suit is not A643. In agreement with that lead, but not quite so positive about it were

PEDEN: ♠3. Partner hasn't doubled diamonds asking for that lead, so I lead spades.

PIPER: ♠3. I presume the ♠10 is correct but too clever for me.

VALENTINE: ♠3. I like an inspired lead as much as the next person, but it is hard to come up with a reason to lead a club. A red suit is out of the question.

ROSS: ♠3. Fourth best of longest and strongest suit.

Still with spades but taking a different tack was

MCGINLEY: ♠A. Then decide which black suit to pursue (it may be a cash-out situation, as the red suits are probably lying well for Declarer).

Nobody was leading hearts on this hand but there were some suggestions of a club lead

SHORT: ♣5. I always want to make an attacking lead in these sorts of situations. An obsession with making a "safe" lead will frequently concede an often vital tempo. There are moments for a safe lead, but these are usually

when the opponents. have obviously stretched to get to game. The auction seems confident here.

WHYTE: ♠T. Eliminate rather than choose. A heart lead is stupid. A spade lead is ill-advised (only a four-card suit, and underleading an Ace very often gives away a trick). A diamond lead is probably hopeless. A club lead is the best chance, you need partner to have only Axxxx, QJxxx, or even Q9xxx if the knave is well-placed for the defence. Having decided the suit, then the card; with honour to three, I generally prefer to lead the smallest card, but here with the Ten there is too much risk of a blockage.

This hand came from the last Tollemache final, and the spade lead let dummy's stiff King win (except against Mike) and that was the ninth trick. A club lead also gives away the vital trick. Across the field six led a spade, seven a diamond.

Problem 8	Votes	Marks
♦ any	7	10
♠3	7	10
♠A	1	4
♣T	1	4
♣5	1	4

Many thanks to the panel again for all the contributions. Well done to Irving Gordon with a high of 77 points, followed in equal second by Douglas Piper and William Ross on 76, and then Iain Sime on 74.

Panel Answers

		1	2	3	4	5	6	7	8	Tot
Top Scoring Choice		Pass	4NT	3♣	Pass	3♦	4♣	4/5♠	♦	
1	Irving Gordon	Pass	4NT	3♣	Pass	Pass	4♣	4♠	♠3	77
2=	William Ross	Pass	4NT	3♣	Dbl	3♦	4♣	4♠	♠3	76
2=	Douglas Piper	Pass	4NT	3♣	Pass	2NT	4♥	4♠	♠3	76
4	Iain Sime	Pass	2♦	Dbl	Pass	3♦	4♣	4♠	♦8	74
5=	Mike Ash	Pass	2♦	3♣	3NT	3♦	4♣	4♠	♦8	73
5=	Miro Dragic	2♠	4NT	Dbl	Pass	3♦	4♥	5♠	♦8	73
7	Ronan Valentine	Pass	4NT	3♣	Dbl	3♦	4♣	5♠	♠3	72
8	Gints Freimanis	Pass	2NT	3♣	Pass	2NT	4♣	4♠	♠3	71
9=	Kay Preddy	Pass	2♦	Dbl	Pass	3♦	4♣	Dbl	♦8	70
9=	Norman Selway	Pass	4NT	3♣	3NT	2NT	4♥	4♥	♦8	70
9=	Tim McKay	Pass	4NT	3♣	Pass	3♦	4♠	4♥	♦8	70
9=	Harry Smith	2♠	4NT	3♣	Dbl	2NT	4♣	5♠	♦8	70
13	Derrick Peden	Pass	2♦	3♣	Pass	2NT	4♥	4♠	♠3	69
14	Robert Clow	Pass	2NT	3♥	Pass	3♦	4♣	5♠	♠3	66
15	Mike McGinley	Pass	4NT	3♣	Pass	4♦	4♥	5♠	♠A	64
16	Brian Short	Pass	2♦	Dbl	Pass	2NT	4♠	4♠	♣5	60
17	William Whyte	2♠	2NT	3NT	Pass	2♥	4♥	5♥	♣T	40

Competitor Results

Congratulations to Douglas Mitchell (Buchanan) on his top score of 75.

Other good scores:

Name	Club	Score
David Welsh	Stirling	72
Ted Black	Buchanan	69
Danny Hamilton	Buchanan	67
Dave Duddell	New Melville	62
Cameron McLatchie	New Melville	61
Alasdair Adam	Direct	57
Alan Paterson	Johnstone	56
Russell Frame	GBC	56
Robin MacPherson	New Melville	54
Anne Perkins	New Melville	53
Janice Thomson	Doon	53
Angela Horsfall	Carlton	52
Bob Brown	New Melville	51

SBNews Bidding Panel Problems

March 2025

You are always South, playing with an excellent first-time partner. You have agreed to play Acol with a weak no-trump.

Please send your answers to the Scorer:

t.vandelisle@gmail.com

quoting your SBU Membership number.

Closing date: 15 March 2025

Problem 1 Teams NS Vul

	S	W	N	E
♠A3				
♥AK	-	-	-	3♣
♦KQT86	?			
♣9753				

You have not agreed to play non-leaping Michaels

Problem 2 Teams NS Vul

	S	W	N	E
♠T5				
♥AKT	-	-	-	P
♦AKJ4	1♣	P	1♥	1NT
♣AK82	Dbl	2♠	P	P
	?			

Problem 3 Teams None Vul

	S	W	N	E
♠KQJ973				
♥AKJ7	-	1♦	P	3♣
♦-	?			
♣K86				

1♦ = Precision, 11-15HCP, 0+diamonds

3♣ = weak with both minors

Problem 4 Teams All Vul

	S	W	N	E
♠96432				
♥AT	-	3♥	P	P
♦8	?			
♣AKQ75				

Problem 5 Teams EW Vul

	S	W	N	E
♠KT95				
♥986	-	-	-	2♥
♦AT53	P	P	3♣	P
♣A3	?			

2♥ = weak

Problem 6 Teams All Vul

	S	W	N	E
♠97				
♥AKQJ92	-	3♣	P	4♣
♦9643	?			
♣2				

Problem 7 Teams NS Vul

	S	W	N	E
♠-				
♥KQ93	1♦	1♠	P	2♦*
♦AK86542	Dbl	4♠	P	P
♣95	?			

2♦ = good spade raise

Problem 8 Teams NS Vul

	S	W	N	E
♠JT732				
♥Q	-	-	-	1NT
♦K632	P	2♣	P	2♥
♣A86	P	3NT	End	

1NT = 15-17. 2♣ = Stayman (why??)

You lead ♠J, which denies a higher honour. (For clarity, your hand has moved to the West seat)

	♠Q95 ♥J32 ♦AQ94 ♣T92	
♠JT732 ♥Q ♦K632 ♣A86		

Trick 1 goes ♠J - ♠5 - ♠8 - ♠A

At Trick 2 declarer leads ♦7 - ♦3 - ♦Q - ♦8

Trick 3 is ♥2 - ♥6 - ♥T - ♥Q

You have agreed standard count.

What do you play now?

Crossword Solution

¹ T	A	² L	K	³ I	N	⁴ G	P	⁵ A	R	⁶ R	O	⁷ T		
E		E		N		A		D		O		H		⁸ K
⁹ L	A	P	U	P		¹⁰ L	A	V	A	L	I	E	R	E
E		E		O		L		E		E		A		Y
¹¹ P	A	R	I	S	M	E	T	R	O		¹² I	N	C	H
H				I		R		T		¹³ C		G		O
¹⁴ O	U	¹⁵ T	S	T	A	Y		¹⁶ S	C	A	F	E	L	L
N		R		I						P		L		E
¹⁷ E	D	I	T	O	R	¹⁸ S		¹⁹ T	R	I	P	S	I	S
K		F		N		C		H		T				U
²⁰ I	D	O	L		²¹ P	O	U	R	P	A	R	²² L	E	R
O		C		²³ P		U		O		L		E		G
²⁴ S	C	A	R	E	C	R	O	W		²⁵ S	H	A	R	E
K		L		K		E		I		U		R		R
		²⁶ S	P	E	N	D	I	N	G	M	O	N	E	Y